



# EVALUATION REPORT

5001 East Philadelphia Street  
Ontario, California – USA 91761-2816  
Ph: 909.472.4100 | Fax: 909.472.4243  
<http://www.iapmortl.org>

**Report Number:** 2295-21879

**Report Issued:** June 2, 2021

**Project No.:** 35996

**Client:** KD Enterprises  
4348 Waialae Ave 315  
Honolulu, HI 96816

**Source of Samples:** Samples were sent to IAPMO R&T Lab from KD Enterprises and received in good condition on 04/13/2021.

**Location of Testing:** IAPMO R&T Lab, 5001 East Philadelphia Street, Ontario CA 91761

**Dates of Evaluation:** May 14-May 24, 2021

**Product Description:** Water conditioning device model 4" WSPS (HDC)

**Primary Standard:** Custom testing procedure outlined below

**Scope of Evaluation:** The purpose of the testing was to determine what effect the samples described above have on reducing the rate of evaporation out of the pool.

**Conclusion:** The pool with the water conditioning device installed had an average of 23% less water loss than the control pool in a period of 9 days.

**Report Status:** COMPLETE

Reviewed By,

Sal Aridi - Director

*All testing and sample preparation for this report was performed under the continuous, direct supervision of IAPMO R&T Lab, unless otherwise stated. The statement of compliance is based on the test results compared to the standard specifications without considering measurement uncertainty. The observations, test results and conclusions in this report apply only to the specific samples tested and are not indicative of the quality or performance of similar or identical products. Only the Client shown above is authorized to copy or distribute the report, and then only in its entirety. Any use of the IAPMO R&T Lab name for the sale or advertisement of the tested material, product or service must first be approved in writing by IAPMO R&T Lab.*



**Objective:** to quantify the amount of water loss in an HDC treated pool versus a pool that is not HDC treated.

**Setup:** For this test two identical pools pool 1 (with the HDC device installed) had 8155 gallons of water and pool 2 (Control) had 8460 gallons of water were set up side-by-side fitted with the same size cartridge filter (Jacuzzi JCA100 and Hayward CC1000) and ran at the same flow rate of 60 gallons per minute (Figures 1-3) . The plumbing was setup so that there are 2 inlets and 3 returns all on 2-inch pipes (Figure 3). Both pools were maintained at the same parameters PH, alkalinity, hardness, and temperature. The only variable was the amount of chlorine (12.5% Sodium Hypochlorite Figure 4) added to each pool to maintain it at a target of three parts per million free available chlorine (Table 5).

The water drop measurements were recorded at four points around the perimeter of each pool at 90° increments (Figure 1). These values are recorded in table 1. The difference between successive dates of measurement at each location is recorded in table 2. Also in table 2 the overall difference in the drop from the the first date to the last date is recorded as 5-24 total. Then the difference in the drop at each point between Pool 1 and Pool 2 was calculated (P2-P1), this difference shows that there was a shift at point 4 in Pool 1 of 0.125 inches. So that difference was backed out of the point 1 drop (5-24 Total adjusted for pool shift) for a net drop of 1.5 inches at point 1. The volumetric change is P1 and P2 was calculated in table 3.



# EVALUATION REPORT

5001 East Philadelphia Street  
 Ontario, California – USA 91761-2816  
 Ph: 909.472.4100 | Fax: 909.472.4243  
<http://www.iapmortl.org>

Point of Measure	P1				P2			
	1	2	3	4	1	2	3	4
15-May	1.875	5.125	9.5	4.625	2	6.375	9.75	5.5
17-May	2.875	5.625	10	5.125	2.5	6.975	10.25	5.78
19-May	2.25	6.125	10.25	5.25	2.75	7.125	10.5	6.125
21-May	2.625	6.25	10.625	5.75	3.125	7.5	10.875	6.5
23-May	3.5	6.875	11.125	6.25	3.635	8.062	11.25	7
24-May	3.25	7	11.25	6.5	3.875	8.25	11.5	7.25

Table 1 – Measured Water Drop in inches from a Fixed Point

Point of Measure	P1				P2			
	1	2	3	4	1	2	3	4
Change (from previous measurement)								
17-May	1	0.5	0.5	0.5	0.5	0.6	0.5	0.28
19-May	-0.625	0.5	0.25	0.125	0.25	0.15	0.25	0.345
21-May	0.375	0.125	0.375	0.5	0.375	0.375	0.375	0.375
23-May	0.875	0.625	0.5	0.5	0.51	0.562	0.375	0.5
24-May	-0.25	0.125	0.125	0.25	0.24	0.188	0.25	0.25
5-24 Total (May 24-May 17)	1.375	1.875	1.75	1.875	1.875	1.875	1.75	1.75
P2-P1 (from 5-24 total)	0.5	0	0	-0.125				
5-24 Total ADJUSTED FOR POOL SHIFT	{1.375-(-0.125)} =1.5				1.875			

Table 2- Drop Changes from Previous Measurement (in Table 1)

Calculations:

		Calculation
AREA OF P1 inches <sup>2</sup>	42822	Top Surface
CHANGE IN P1 VOL inches <sup>3</sup>	64233	42822 x 1.5
GAL LOST FROM P1	278	64533 in <sup>3</sup> /231 (in <sup>3</sup> /gal)
AREA OF P2 inches <sup>2</sup>	44675	Top Surface
CHANGE IN P2 VOL inches <sup>3</sup>	83766	44675 x 1.875
GAL LOST FROM P2	363	83766 in <sup>3</sup> /231 (in <sup>3</sup> /gal)
<b>Vol Change</b>	<b>23%</b>	<b>1-(278/363)</b>

Table 3- Calculations for Percentage Difference



Figure 1 – Two Pools Layout



Figure 2- Device Under Test

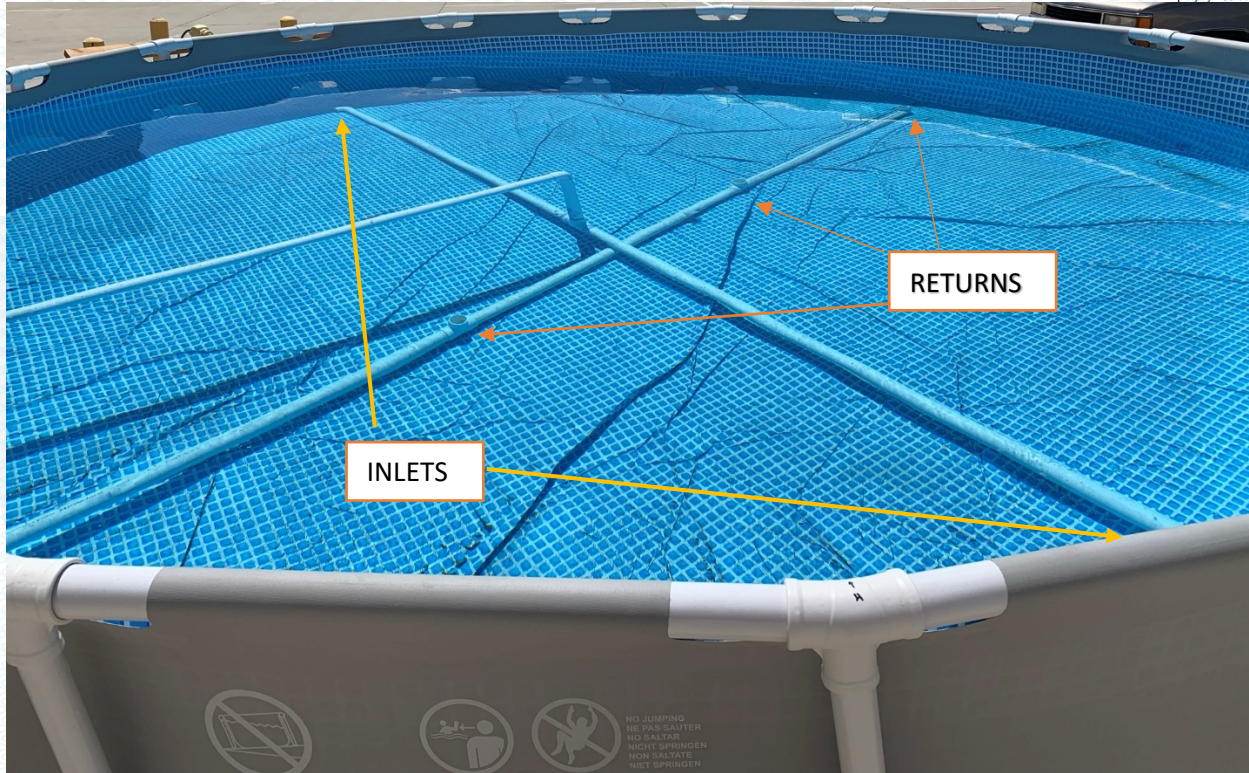

Figure 3- Layout of Inlets and Returns- Same for Both Pools



# EVALUATION REPORT

5001 East Philadelphia Street  
Ontario, California – USA 91761-2816  
Ph: 909.472.4100 | Fax: 909.472.4243  
<http://www.iapmortl.org>

**Report Number:** 2295-21872

**Report Issued:** May 28, 2021

**Project No.:** 35996

**Client:** KD Enterprises  
4348 Waialae Ave 315  
Honolulu, HI 96816

**Source of Samples:** Samples were sent to IAPMO R&T Lab from KD Enterprises and received in good condition on 04/13/2021.

**Location of Testing:** IAPMO R&T Lab, 5001 East Philadelphia Street, Ontario CA 91761

**Dates of Evaluation:** May 14-May 24, 2021

**Product Description:** Water conditioning device model 4" WSPS (HDC)

**Primary Standard:** Custom testing procedure outlined below

**Scope of Evaluation:** The purpose of the testing was to determine what effect the samples described above have on reducing combined chlorine above have any effect on reducing combined chlorine.

**Conclusion:** The pool with the water conditioning device installed had an average of 36% less combined chlorine than the control pool.

**Report Status:** COMPLETE

Reviewed By,

Sal Aridi - Director

*All testing and sample preparation for this report was performed under the continuous, direct supervision of IAPMO R&T Lab, unless otherwise stated. The statement of compliance is based on the test results compared to the standard specifications without considering measurement uncertainty. The observations, test results and conclusions in this report apply only to the specific samples tested and are not indicative of the quality or performance of similar or identical products. Only the Client shown above is authorized to copy or distribute the report, and then only in its entirety. Any use of the IAPMO R&T Lab name for the sale or advertisement of the tested material, product or service must first be approved in writing by IAPMO R&T Lab.*



**Objective:** to quantify the amount of combined chlorine produced in an HDC treated pool versus a pool that is not HDC treated.

**Setup:** For this test two identical pools pool 1 (with the HDC device installed) had 8155 gallons of water and pool 2 (Control) had 8460 gallons of water were set up side-by-side fitted with the same size cartridge filter (Jacuzzi JCA100 and Hayward CC1000) and ran at the same flow rate of 60 gallons per minute (Figures 1-3) . The plumbing was setup so that there are 2 inlets and 3 returns all on 2-inch pipes (Figure 8). Both pools were maintained at the same parameters PH, alkalinity, hardness, and temperature. The only variable was the amount of chlorine (12.5% Sodium Hypochlorite Figure 4) added to each pool to maintain it at a target of three parts per million free available chlorine (Table 5).

Samples were taken from the return pipe downstream of the HDC device and from the return pipe of the control pool that does not have an HDC device. The samples were analyzed for free (Graph 1) and total chlorine (Graph 2) using HACH DPD pillows, the difference between the two readings is the combined chlorine (Graph 3). Combined chlorine is made of Chloramines, these are undesirable forms of chlorine that result from the combination of chlorine and the contaminants in the pool that are mainly coming from bather load: Urine / sweat / skin / fecal matter etc. In an ideal pool the combined chlorine levels are maintained below 0.5 ppm. In order to simulate some of this bather load a combination of chemicals (Table 1) were added to each pool in equal amounts at the same time (Figure 5). On the days bather load was introduced the amount was equivalent to 100 hours of bathers thrown in a single dose.

Table 1 – Amount of Chemicals in Each Dose of Bather Load

<b>Chemical</b>	<b>Amount</b>
Albumin	9.75 gm
Creatinine	4.25 gm
Ammonium Chloride	10 gm
Urea	30 gm

Table 2 details the events of the test, in preparation for the test, the 2 pools were conditioned by adding equal amounts (2 gallons each) of Instant Balancer muriatic acid.

**Observations:** The combined chlorines for the HDC pool were consistently lower than the control pool especially after adding the chlorine. Figures 6 and 7 show the difference in the dissipation of the bather load observed after several days of running the pools. When the addition of bather stopped the variation between the 2 pools dropped off. The HDC treated pool used 0.3% less chlorine than the control pool.





# EVALUATION REPORT

5001 East Philadelphia Street  
 Ontario, California – USA 91761-2816  
 Ph: 909.472.4100 | Fax: 909.472.4243  
<http://www.iapmortl.org>

Table 2 – Data and Chronology of Events

Date	Time	Event	P1-HDC					P2-CNTRL				
			FAC (ppm)	TC (ppm)	COMB (ppm)	ORP	pH	FAC (ppm)	TC (ppm)	COMB (ppm)	ORP	pH
18-May	10:15 AM		2.40	2.74	0.34	640	7.67	2.56	3.14	0.58	639	7.65
	10:55 AM	Added Chlorine to pools										
	1:15 PM		2.58	2.86	0.28	649	7.52	2.60	3.04	0.44	644	7.51
	1:40 PM	Bather load added										
	2:50 PM		1.34	2.20	0.86	626	7.45	1.30	2.90	1.60	625	7.44
	3:25 AM	Added Chlorine to pools										
	4:15 PM		1.54	2.58	1.04	641	7.45	1.96	2.84	0.88	635	7.45
	6:35 PM		1.66	2.86	1.2	674	7.38	1.68	2.94	1.26	681	7.37
	7:00 PM	Added Chlorine to pools										
19-May	8:50 AM		2.10	2.72	0.62	618	7.28	1.68	2.90	1.22	620	7.28
	9:20 AM	Added Chlorine to pools										
	11:25 AM		2.00	3.04	1.04	603	7.54	2.06	2.98	0.92	601	7.55
	12:00 PM	Added Chlorine to pools										
	1:15 PM		2.76	3.08	0.32	607	7.56	1.28	3.16	1.88	600	7.55
	2:45 PM		2.40	2.58	0.18	608	7.52	2.26	2.82	0.56	603	7.51
	3:15 PM	Added Chlorine to pools										
	3:20 PM	Bather load added										
	4:30 PM		1.60	1.84	0.24	615	7.47	1.86	2.16	0.30	598	7.47
	4:50 PM	Added Chlorine to pools										



# EVALUATION REPORT

5001 East Philadelphia Street  
 Ontario, California – USA 91761-2816  
 Ph: 909.472.4100 | Fax: 909.472.4243  
<http://www.iapmortl.org>

20-May	8:45 AM		1.98	1.98	0.00			1.54	2.38	0.84		
	9:25 AM		1.86	2.02	0.16			1.62	1.96	0.34		
	9:45 AM					589	7.35				593	7.55
	9:45 AM	Added Chlorine to pools										
	11:15 AM		1.86	2.44	0.58	589	7.47	2.20	2.68	0.48	589	7.50
	12:00 PM		1.92	2.36	0.44	587	7.55	2.32	2.52	0.20	575	7.54
	12:15 PM	Added Chlorine to pools										
	3:45 PM		1.88	2.26	0.38	583	7.58	1.78	2.44	0.66	593	7.57
	5:00 PM	Added Chlorine to pools										
			FAC	TC	COMB	ORP	pH	FAC	TC	COMB	ORP	pH
	5:30 PM	Bather load added										
21-May	8:15 AM		1.18	1.44	0.26	599	7.34	1.02	1.52	0.5	601	7.33
	8:35 AM	Added Chlorine to pools										
	11:30 AM		1.42	1.94	0.52	607	7.65	1.48	2.10	0.62	600	7.64
	11:50 AM	Added Chlorine to pools										
	3:25 PM		1.91	1.98	0.07	606	7.58	2.02	2.10	0.08	606	7.58
	4:10 PM	Added Chlorine to pools										
	5:20 PM	Bather load added										
22-May	9:00 AM		0.93	1.10	0.17	533	7.61	1.01	1.14	0.13	546	7.68
	9:20 AM		0.91	1.05	0.14			0.91	1.08	0.17		
	9:50 AM	Added Chlorine to pools										
	3:00 PM		1.21	1.33	0.12	587	7.64	1.30	1.41	0.11	586	7.64
	3:30 PM		1.22	1.33	0.11			1.19	1.38	0.19		
	3:40 PM	Added Chlorine to pools										
23-May	10:30 AM		0.95	1.04	0.09	535	7.72	0.98	1.14	0.16	534	7.70



# EVALUATION REPORT

5001 East Philadelphia Street  
 Ontario, California – USA 91761-2816  
 Ph: 909.472.4100 | Fax: 909.472.4243  
<http://www.iapmortl.org>

	11:15 AM	Added Chlorine to pools											
	11:55 AM		1.52	1.63	0.11		7.70	1.51	1.66	0.15			7.72
	12:05 PM	Added Chlorine to pools											
	12:25 PM		1.68	2.10	0.42	576		1.44	2.10	0.66	577		
	1:00 PM		1.80	2.00	0.20	574		1.88	2.28	0.40	570		
24-May	9:25 AM		1.13	1.23	0.10	532	7.70	1.18	1.27	0.09	532	7.69	
	10:07 AM	Added Chlorine to pools											
	10:30 AM		1.50	1.78	0.28			1.46	2.02	0.56			
<i>Combined Chlorine Averages</i>					0.37					0.57			
		<b>Average Reduction in Combined Chlorine</b>						<b>36%</b>					

Table 3 – Operational Parameters

	18-May		19-May		20-May		21-May		22-May		23-May		24-May	
	P1	P2	P1	P2	P1	P2	P1	P2	P1	P2	P1	P2	P1	P2
pH	7.52	7.51	7.54	7.55	7.35	7.55	7.58	7.58	7.61	7.68	7.72	7.70	7.70	7.69
Tot Alkalinity ppm	145	150	146	151	150	NR	145	147	145	155	152	156	151	152
Hardness ppm			188.1	188.1			188.1	171	171	171	188.1	188.1		
ORP	649	644	603	601	589	593	606	606	533	546	535	534	532	532
Flowrate gpm	60	60	60	60	60	60	60	60	60	60	60	60	60	60
TDS ppm	312	316	323	325	336	336	347	346	357	357	364	366	369	374
Turbidity NTU							0.23	0.09					0.22	0.25
Pressure psi	12	11	12	11	12	11	12	11	12	11	12	11	12	11



# EVALUATION REPORT

5001 East Philadelphia Street  
 Ontario, California – USA 91761-2816  
 Ph: 909.472.4100 | Fax: 909.472.4243  
<http://www.iapmortl.org>

Table 4 – Ambient Data

	18-May		19-May		20-May	21-May		22-May	23-May		24-May
Air Temp °F	78.3	73.8	67.1	84.2	74.2	63	77.8	71.1	80	87.9	93.4
Wet Bulb °F	68.6	63.8	61.5	67.4	63.1	54.7	59.1	56.8	65	66.2	70.2
Relative Humidity %	61.0	57.7	72.9	41.2	53.7	58.4	30.9	39.8	44.0	30.4	30.6

Table 5- Chlorine Consumption Data

	Chorine Consumption				
	Date	Time	P1-HDC	P2-CNTRL	
ml CL Added	18-May	10:55 AM	150	130	
	18-May	3:25 PM	410	420	
	18-May	7:00 PM	330	330	
	19-May	9:20 AM	220	330	
	19-May	12:00 PM	250	230	
	19-May	3:15 PM	150	180	
	19-May	4:50 PM	350	280	
	20-May	9:45 AM	280	340	
	20-May	12:15 PM	270	170	
	20-May	5:00 PM	280	300	
	21-May	8:35 AM	450	490	
	21-May	11:50 AM	390	380	
	21-May	4:10 PM	270	240	
	22-May	9:50 AM	490	490	
	22-May	3:40 PM	300	300	
	23-May	11:15 AM	400	400	
	23-May	12:05 PM	400	400	
	24-May	10:07 AM	400	400	
		Total		5790	5810
	<b>Additional Chlorine added to P2 vs P1</b>				<b>0.3%</b>

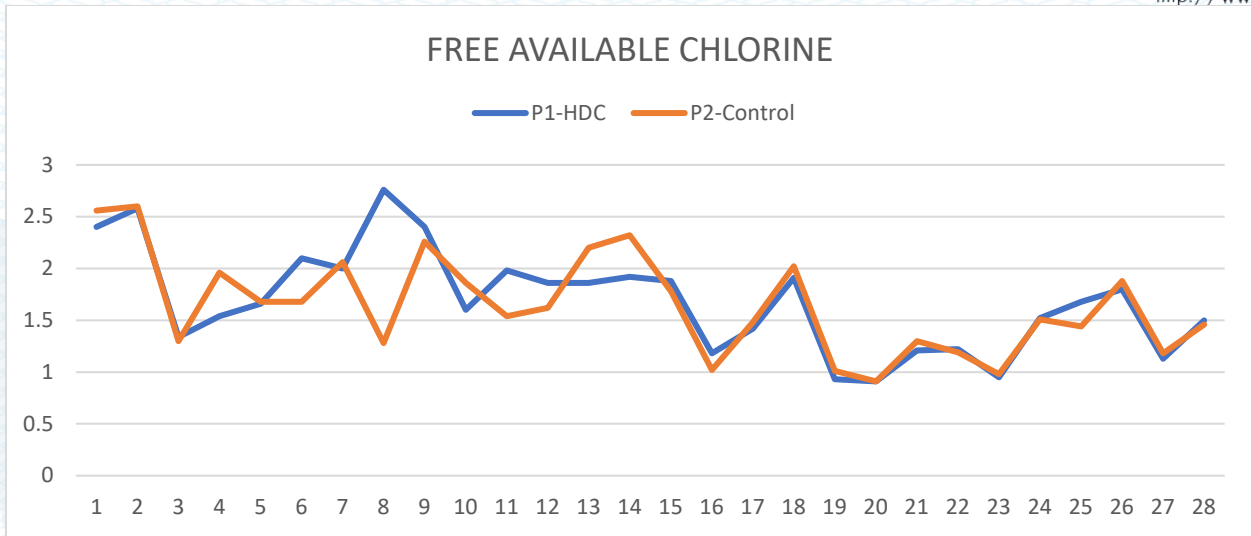

Graph 1- The FAC data taken in Both Pools

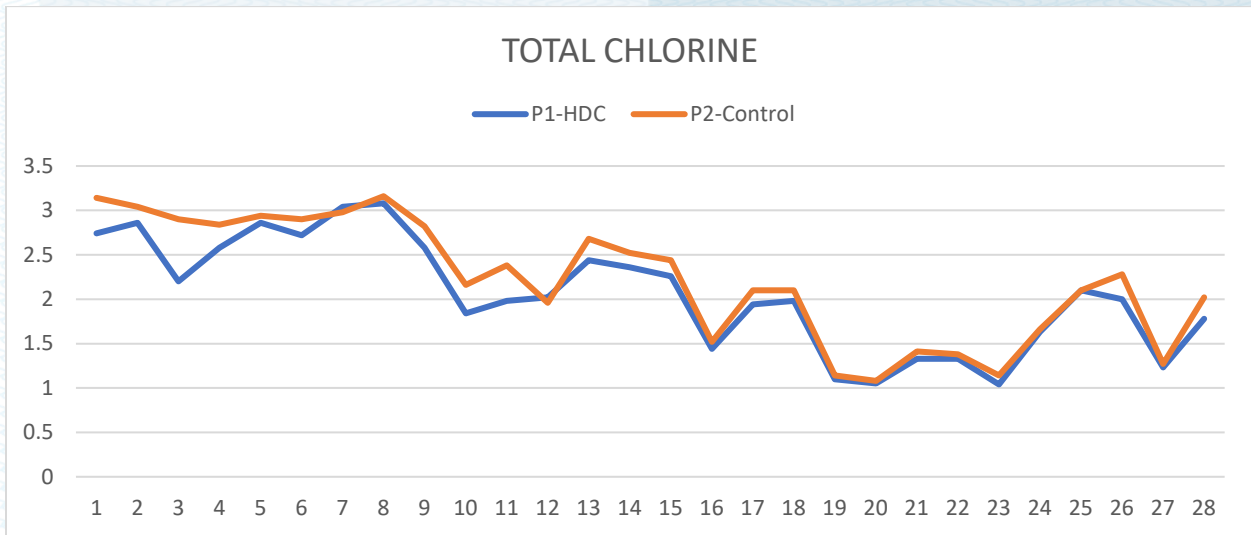

Graph 2- Total Chlorine in Both Pools

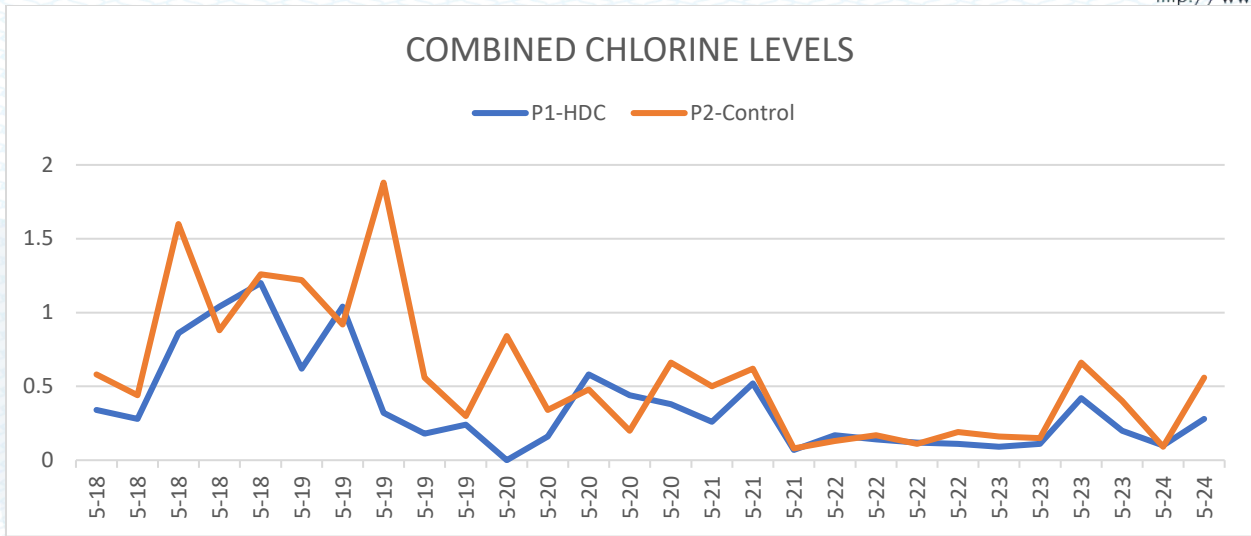

Graph 3 – The Combined Chlorine in Both Pools

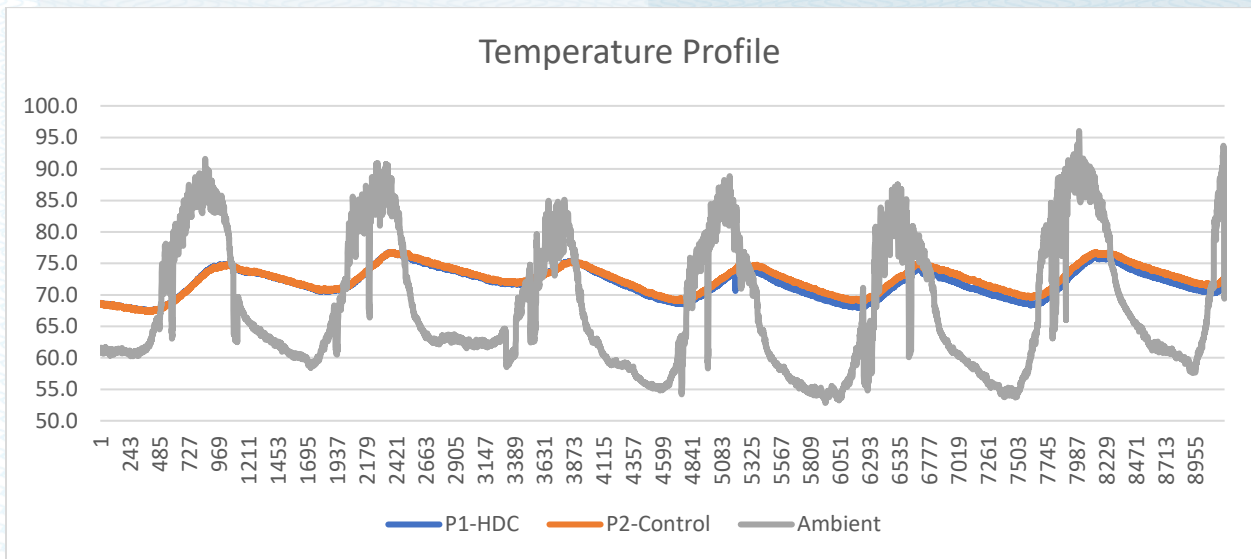

Graph 4 – the Temperature of the Water in Both Pools and the Ambient Temperature (the dips in the ambient are the wet bulb temperatures for calculating Relative Humidity)



Figure 1 – Two Pools Layout



Figure 2 – Two Pools Layout



Figure 3- Device Under Test



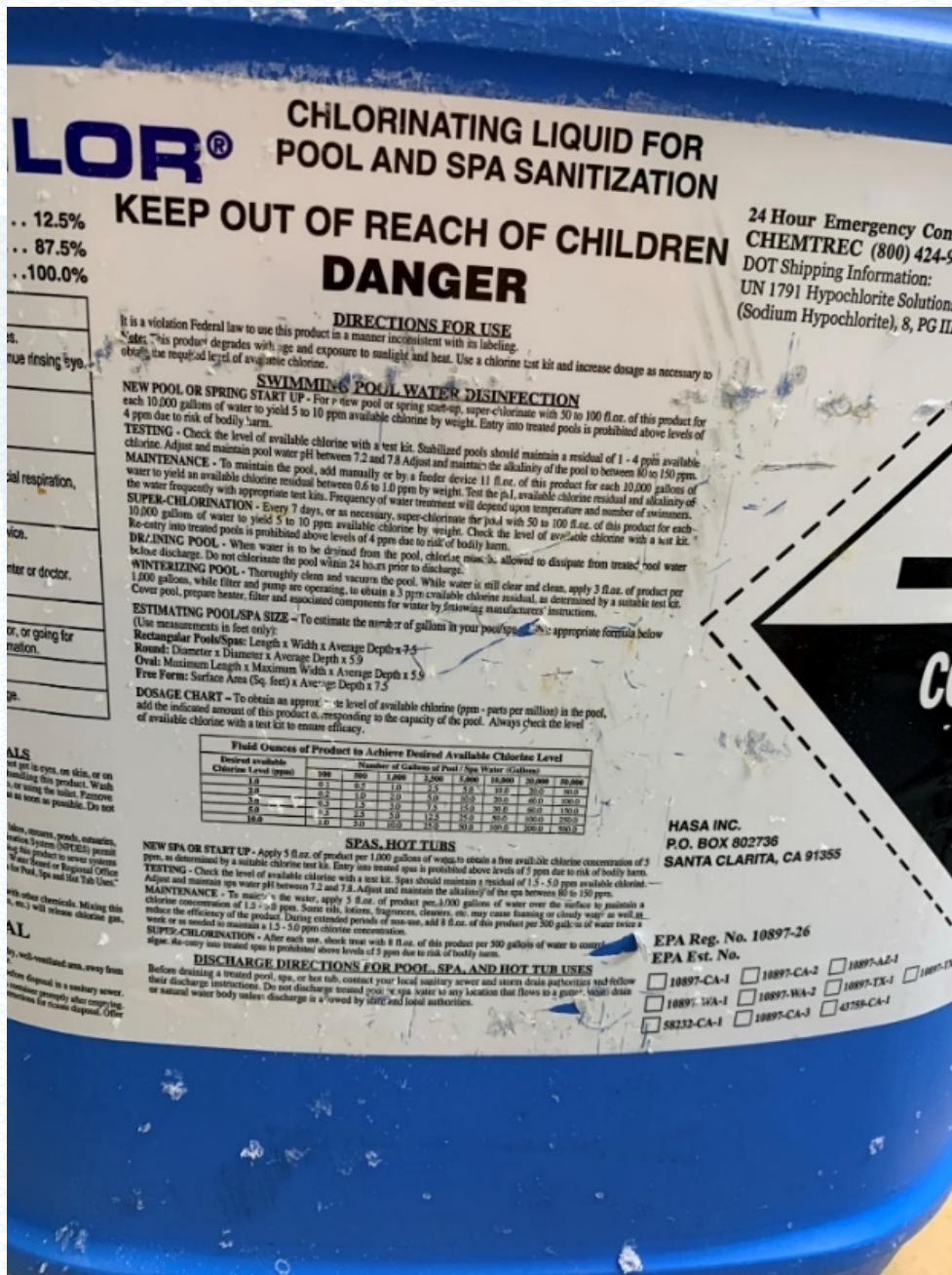

Figure 4 – Chlorine Used

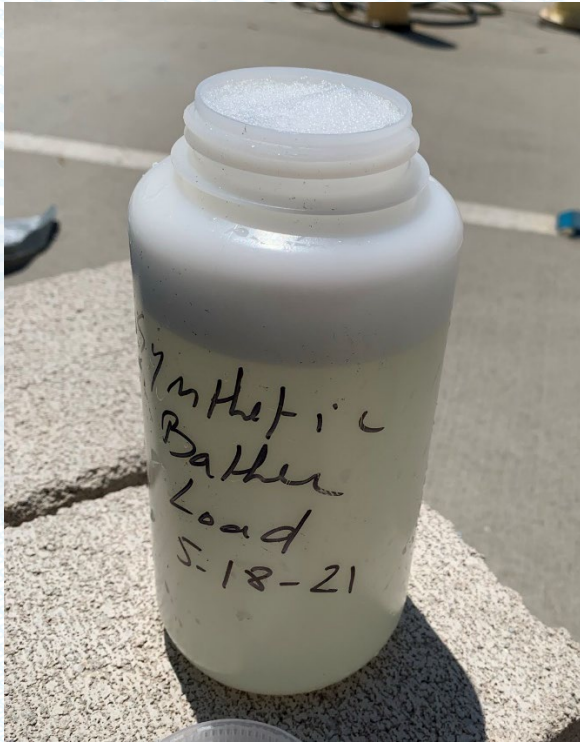

Figure 5 – Bather Load After Mixing With Pool Water



Figure 6- HDC Treated Pool After 1.25 Hours of Introducing the Bather load



Figure 7 – Control Pool After 1.25 hrs of Introducing the Bather Load – Material Still Floating

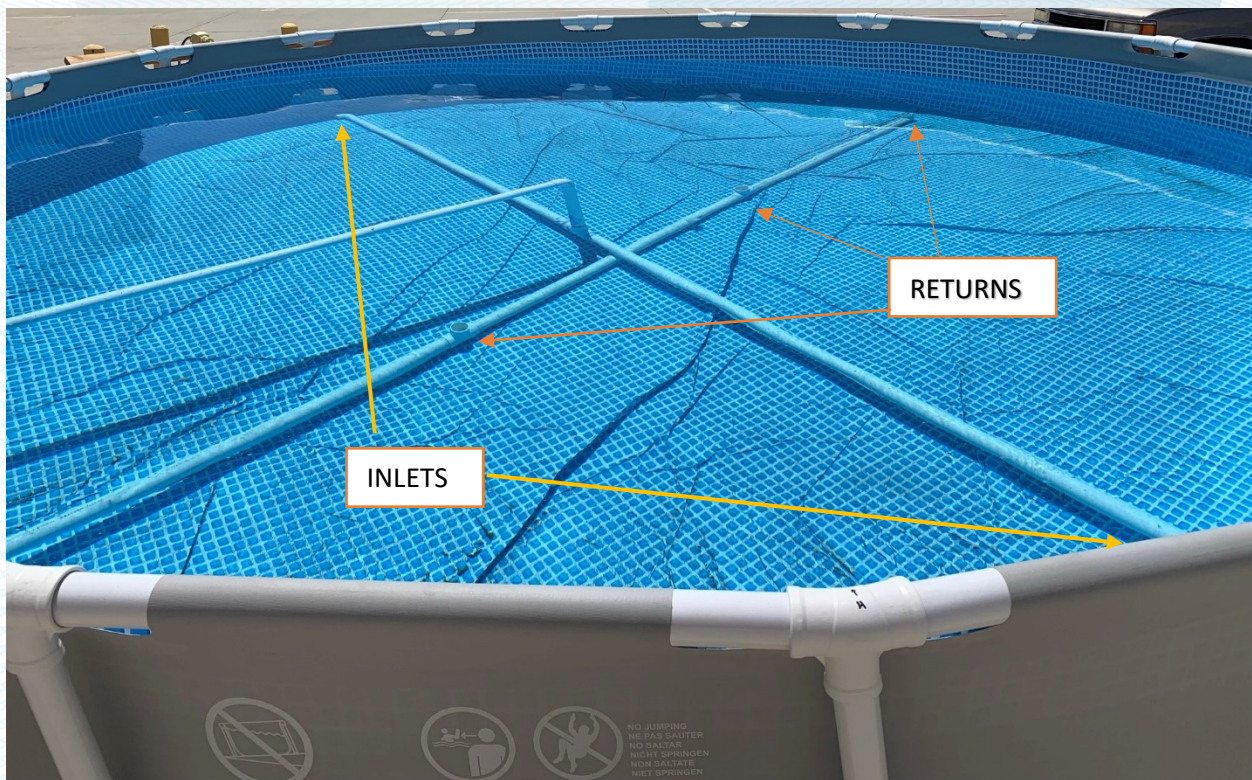

Figure 8- Layout of Inlets and Returns- Same for Both Pools



# EVALUATION REPORT

5001 East Philadelphia Street  
Ontario, California – USA 91761-2816  
Ph: 909.472.4100 | Fax: 909.472.4243  
<http://www.iapmortl.org>

**Report Number:** 2295-21884

**Report Issued:** June 4, 2021

**Project No.:** 35996

**Client:** KD Enterprises  
4348 Waialae Ave 315  
Honolulu, HI 96816

**Source of Samples:** Samples were sent to IAPMO R&T Lab from KD Enterprises and received in good condition on 04/13/2021.

**Location of Testing:** IAPMO R&T Lab, 5001 East Philadelphia Street, Ontario CA 91761

**Dates of Evaluation:** May 14-May 24, 2021

**Product Description:** Water conditioning device model 4" WSPS (HDC)

**Primary Standard:** Custom testing procedure outlined below

**Scope of Evaluation:** The purpose of the testing was to determine what effect the samples described above have on reducing combined chlorine.

**Conclusion:** The pool with the water conditioning device installed had an average of 36% less combined chlorine than the control pool.

**Report Status:** COMPLETE

Reviewed By,

Sal Aridi - Director

*This report replaces report number 2295-21872. It was reissued to correct an editorial in the scope of evaluation on page 1 and to add a reference to NSF 50 listing under Observations on page 2.*

*All testing and sample preparation for this report was performed under the continuous, direct supervision of IAPMO R&T Lab, unless otherwise stated. The statement of compliance is based on the test results compared to the standard specifications without considering measurement uncertainty. The observations, test results and conclusions in this report apply only to the specific samples tested and are not indicative of the quality or performance of similar or identical products. Only the Client shown above is authorized to copy or distribute the report, and then only in its entirety. Any use of the IAPMO R&T Lab name for the sale or advertisement of the tested material, product or service must first be approved in writing by IAPMO R&T Lab.*



**Objective:** to quantify the amount of combined chlorine produced in an HDC treated pool versus a pool that is not HDC treated.

**Setup:** For this test two identical pools pool 1 (with the HDC device installed) had 8155 gallons of water and pool 2 (Control) had 8460 gallons of water were set up side-by-side fitted with the same size cartridge filter (Jacuzzi JCA100 and Hayward CC1000) and ran at the same flow rate of 60 gallons per minute (Figures 1-3) . The plumbing was setup so that there are 2 inlets and 3 returns all on 2-inch pipes (Figure 8). Both pools were maintained at the same parameters PH, alkalinity, hardness, and temperature. The only variable was the amount of chlorine (12.5% Sodium Hypochlorite Figure 4) added to each pool to maintain it at a target of three parts per million free available chlorine (Table 5).

Samples were taken from the return pipe downstream of the HDC device and from the return pipe of the control pool that does not have an HDC device. The samples were analyzed for free (Graph 1) and total chlorine (Graph 2) using HACH DPD pillows, the difference between the two readings is the combined chlorine (Graph 3). Combined chlorine is made of Chloramines, these are undesirable forms of chlorine that result from the combination of chlorine and the contaminants in the pool that are mainly coming from bather load: Urine / sweat / skin / fecal matter etc. In an ideal pool the combined chlorine levels are maintained below 0.5 ppm. In order to simulate some of this bather load a combination of chemicals (Table 1) were added to each pool in equal amounts at the same time (Figure 5). On the days bather load was introduced the amount was equivalent to 100 hours of bathers thrown in a single dose.

Table 1 – Amount of Chemicals in Each Dose of Bather Load

<b>Chemical</b>	<b>Amount</b>
Albumin	9.75 gm
Creatinine	4.25 gm
Ammonium Chloride	10 gm
Urea	30 gm

Table 2 details the events of the test, in preparation for the test, the 2 pools were conditioned by adding equal amounts (2 gallons each) of Instant Balancer muriatic acid.

**Observations:** The combined chlorines for the HDC pool were consistently lower than the control pool especially after adding the chlorine. Figures 6 and 7 show the difference in the dissipation of the bather load observed after several days of running the pools. When the addition of bather stopped the variation between the 2 pools dropped off. The HDC treated pool used 0.3% less chlorine than the control pool.

Note that this device is listed to NSF 50 under report number 2295-20498.



# EVALUATION REPORT

5001 East Philadelphia Street  
 Ontario, California – USA 91761-2816  
 Ph: 909.472.4100 | Fax: 909.472.4243  
<http://www.iapmortl.org>

Table 2 – Data and Chronology of Events

Date	Time	Event	P1-HDC					P2-CNTRL				
			FAC (ppm)	TC (ppm)	COMB (ppm)	ORP	pH	FAC (ppm)	TC (ppm)	COMB (ppm)	ORP	pH
18-May	10:15 AM		2.40	2.74	0.34	640	7.67	2.56	3.14	0.58	639	7.65
	10:55 AM	Added Chlorine to pools										
	1:15 PM		2.58	2.86	0.28	649	7.52	2.60	3.04	0.44	644	7.51
	1:40 PM	Bather load added										
	2:50 PM		1.34	2.20	0.86	626	7.45	1.30	2.90	1.60	625	7.44
	3:25 AM	Added Chlorine to pools										
	4:15 PM		1.54	2.58	1.04	641	7.45	1.96	2.84	0.88	635	7.45
	6:35 PM		1.66	2.86	1.2	674	7.38	1.68	2.94	1.26	681	7.37
	7:00 PM	Added Chlorine to pools										
19-May	8:50 AM		2.10	2.72	0.62	618	7.28	1.68	2.90	1.22	620	7.28
	9:20 AM	Added Chlorine to pools										
	11:25 AM		2.00	3.04	1.04	603	7.54	2.06	2.98	0.92	601	7.55
	12:00 PM	Added Chlorine to pools										
	1:15 PM		2.76	3.08	0.32	607	7.56	1.28	3.16	1.88	600	7.55
	2:45 PM		2.40	2.58	0.18	608	7.52	2.26	2.82	0.56	603	7.51
	3:15 PM	Added Chlorine to pools										
	3:20 PM	Bather load added										
	4:30 PM		1.60	1.84	0.24	615	7.47	1.86	2.16	0.30	598	7.47
	4:50 PM	Added Chlorine to pools										
20-May	8:45 AM		1.98	1.98	0.00			1.54	2.38	0.84		
	9:25 AM		1.86	2.02	0.16			1.62	1.96	0.34		



# EVALUATION REPORT

5001 East Philadelphia Street  
Ontario, California – USA 91761-2816

Ph: 909.472.4100 | Fax: 909.472.4243  
<http://www.iapmortl.org>

	9:45 AM					589	7.35				593	7.55
	9:45 AM	Added Chlorine to pools										
	11:15 AM		1.86	2.44	0.58	589	7.47	2.20	2.68	0.48	589	7.50
	12:00 PM		1.92	2.36	0.44	587	7.55	2.32	2.52	0.20	575	7.54
	12:15 PM	Added Chlorine to pools										
	3:45 PM		1.88	2.26	0.38	583	7.58	1.78	2.44	0.66	593	7.57
	5:00 PM	Added Chlorine to pools										
			FAC	TC	COMB	ORP	pH	FAC	TC	COMB	ORP	pH
	5:30 PM	Bather load added										
21-May	8:15 AM		1.18	1.44	0.26	599	7.34	1.02	1.52	0.5	601	7.33
	8:35 AM	Added Chlorine to pools										
	11:30 AM		1.42	1.94	0.52	607	7.65	1.48	2.10	0.62	600	7.64
	11:50 AM	Added Chlorine to pools										
	3:25 PM		1.91	1.98	0.07	606	7.58	2.02	2.10	0.08	606	7.58
	4:10 PM	Added Chlorine to pools										
	5:20 PM	Bather load added										
22-May	9:00 AM		0.93	1.10	0.17	533	7.61	1.01	1.14	0.13	546	7.68
	9:20 AM		0.91	1.05	0.14			0.91	1.08	0.17		
	9:50 AM	Added Chlorine to pools										
	3:00 PM		1.21	1.33	0.12	587	7.64	1.30	1.41	0.11	586	7.64
	3:30 PM		1.22	1.33	0.11			1.19	1.38	0.19		
	3:40 PM	Added Chlorine to pools										
23-May	10:30 AM		0.95	1.04	0.09	535	7.72	0.98	1.14	0.16	534	7.70



# EVALUATION REPORT

5001 East Philadelphia Street  
 Ontario, California – USA 91761-2816  
 Ph: 909.472.4100 | Fax: 909.472.4243  
<http://www.iapmortl.org>

	11:15 AM	Added Chlorine to pools											
	11:55 AM		1.52	1.63	0.11		7.70	1.51	1.66	0.15			7.72
	12:05 PM	Added Chlorine to pools											
	12:25 PM		1.68	2.10	0.42	576		1.44	2.10	0.66		577	
	1:00 PM		1.80	2.00	0.20	574		1.88	2.28	0.40		570	
24-May	9:25 AM		1.13	1.23	0.10	532	7.70	1.18	1.27	0.09		532	7.69
	10:07 AM	Added Chlorine to pools											
	10:30 AM		1.50	1.78	0.28			1.46	2.02	0.56			
<i>Combined Chlorine Averages</i>					0.37					0.57			
		<b>Average Reduction in Combined Chlorine</b>					<b>36%</b>						

Table 3 – Operational Parameters

	18-May		19-May		20-May		21-May		22-May		23-May		24-May	
	P1	P2	P1	P2	P1	P2	P1	P2	P1	P2	P1	P2	P1	P2
pH	7.52	7.51	7.54	7.55	7.35	7.55	7.58	7.58	7.61	7.68	7.72	7.70	7.70	7.69
Tot Alkalinity ppm	145	150	146	151	150	NR	145	147	145	155	152	156	151	152
Hardness ppm			188.1	188.1			188.1	171	171	171	188.1	188.1		
ORP	649	644	603	601	589	593	606	606	533	546	535	534	532	532
Flowrate gpm	60	60	60	60	60	60	60	60	60	60	60	60	60	60
TDS ppm	312	316	323	325	336	336	347	346	357	357	364	366	369	374
Turbidity NTU							0.23	0.09					0.22	0.25
Pressure psi	12	11	12	11	12	11	12	11	12	11	12	11	12	11





# EVALUATION REPORT

5001 East Philadelphia Street  
 Ontario, California – USA 91761-2816  
 Ph: 909.472.4100 | Fax: 909.472.4243  
<http://www.iapmortl.org>

Table 4 – Ambient Data

	18-May		19-May		20-May	21-May		22-May	23-May		24-May
Air Temp °F	78.3	73.8	67.1	84.2	74.2	63	77.8	71.1	80	87.9	93.4
Wet Bulb °F	68.6	63.8	61.5	67.4	63.1	54.7	59.1	56.8	65	66.2	70.2
Relative Humidity %	61.0	57.7	72.9	41.2	53.7	58.4	30.9	39.8	44.0	30.4	30.6

Table 5- Chlorine Consumption Data

	Chorine Consumption				
	Date	Time	P1-HDC	P2-CNTRL	
ml CL Added	18-May	10:55 AM	150	130	
	18-May	3:25 PM	410	420	
	18-May	7:00 PM	330	330	
	19-May	9:20 AM	220	330	
	19-May	12:00 PM	250	230	
	19-May	3:15 PM	150	180	
	19-May	4:50 PM	350	280	
	20-May	9:45 AM	280	340	
	20-May	12:15 PM	270	170	
	20-May	5:00 PM	280	300	
	21-May	8:35 AM	450	490	
	21-May	11:50 AM	390	380	
	21-May	4:10 PM	270	240	
	22-May	9:50 AM	490	490	
	22-May	3:40 PM	300	300	
	23-May	11:15 AM	400	400	
	23-May	12:05 PM	400	400	
	24-May	10:07 AM	400	400	
		Total		5790	5810
	<b>Additional Chlorine added to P2 vs P1</b>				<b>0.3%</b>

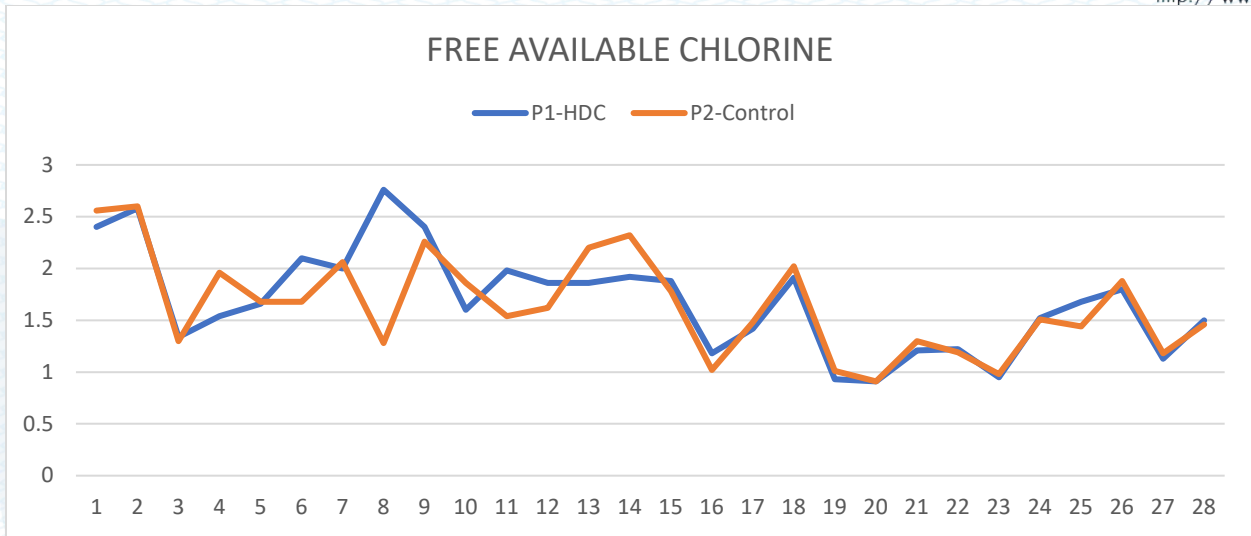

Graph 1- The FAC data taken in Both Pools

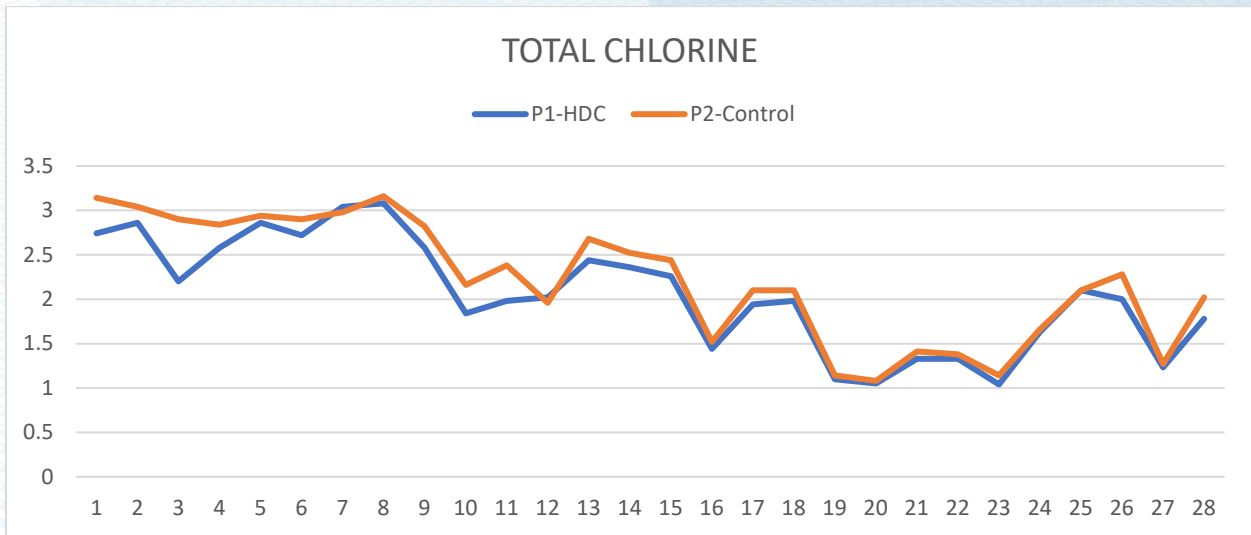

Graph 2- Total Chlorine in Both Pools

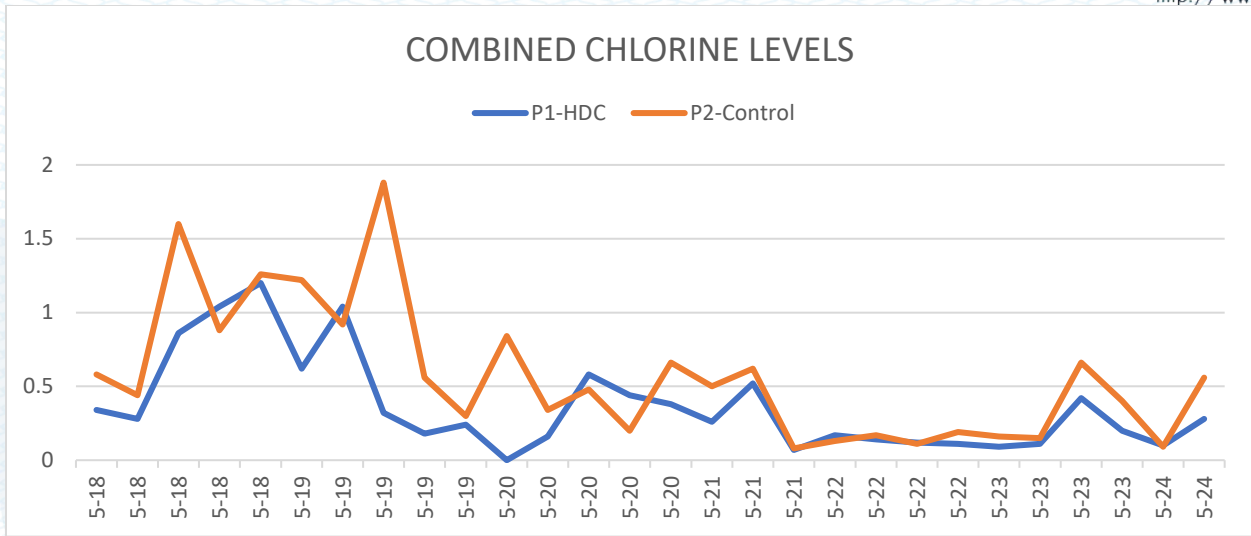

Graph 3 – The Combined Chlorine in Both Pools

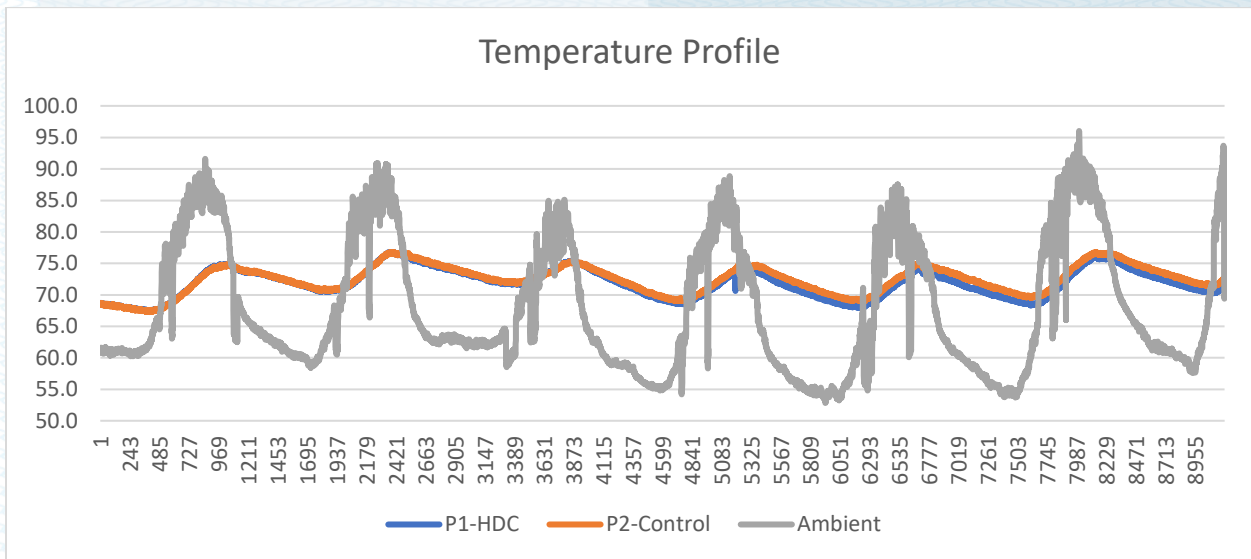

Graph 4 – the Temperature of the Water in Both Pools and the Ambient Temperature (the dips in the ambient are the wet bulb temperatures for calculating Relative Humidity)



Figure 1 – Two Pools Layout



Figure 2 – Two Pools Layout



Figure 3- Device Under Test

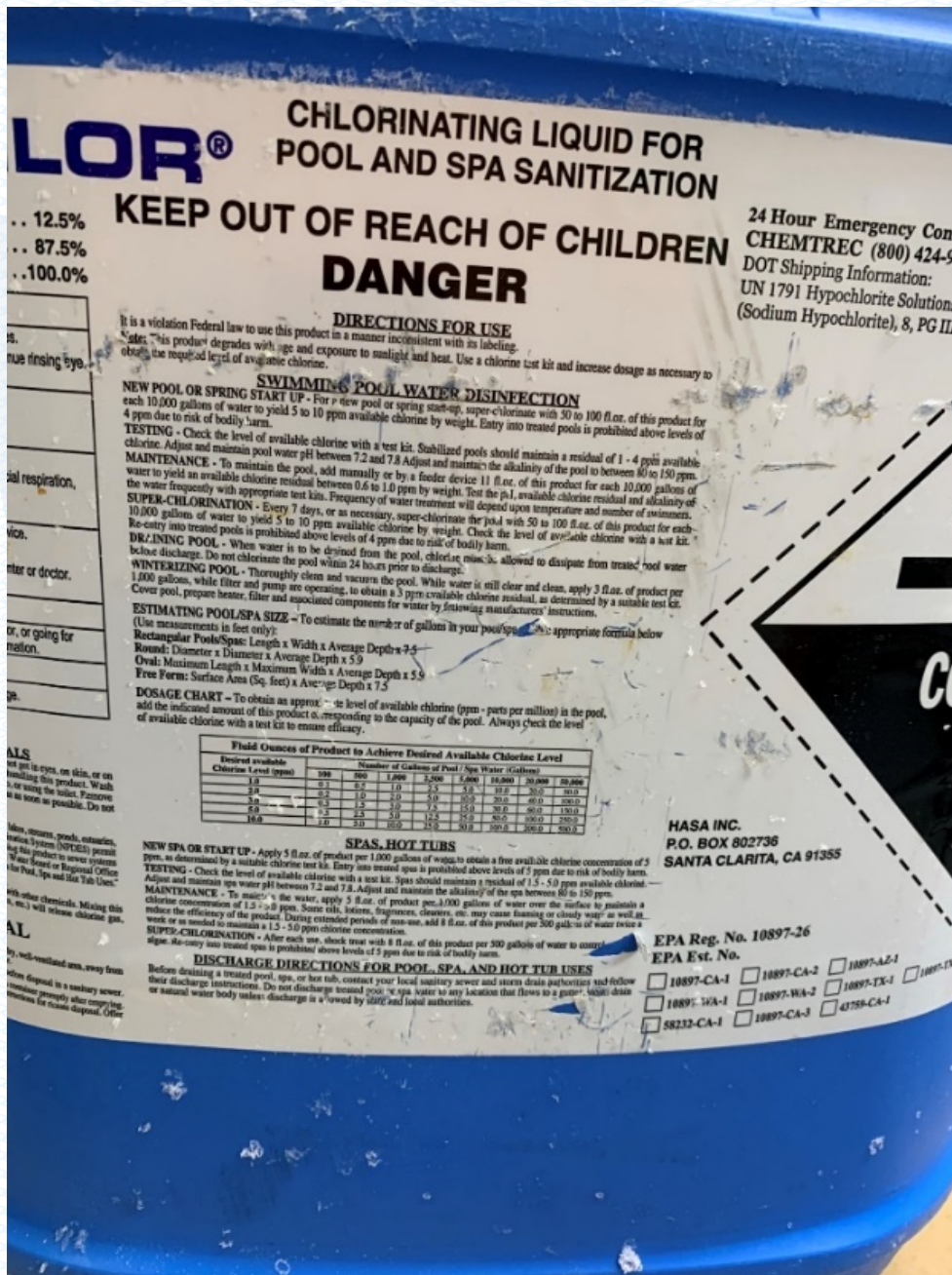

Figure 4 – Chlorine Used

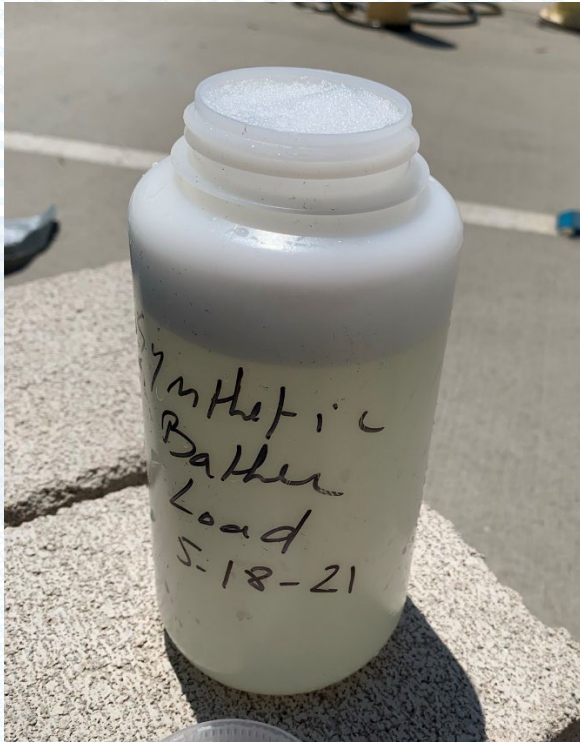

Figure 5 – Bather Load After Mixing With Pool Water



Figure 6- HDC Treated Pool After 1.25 Hours of Introducing the Bather load



Figure 7 – Control Pool After 1.25 hrs of Introducing the Bather Load – Material Still Floating

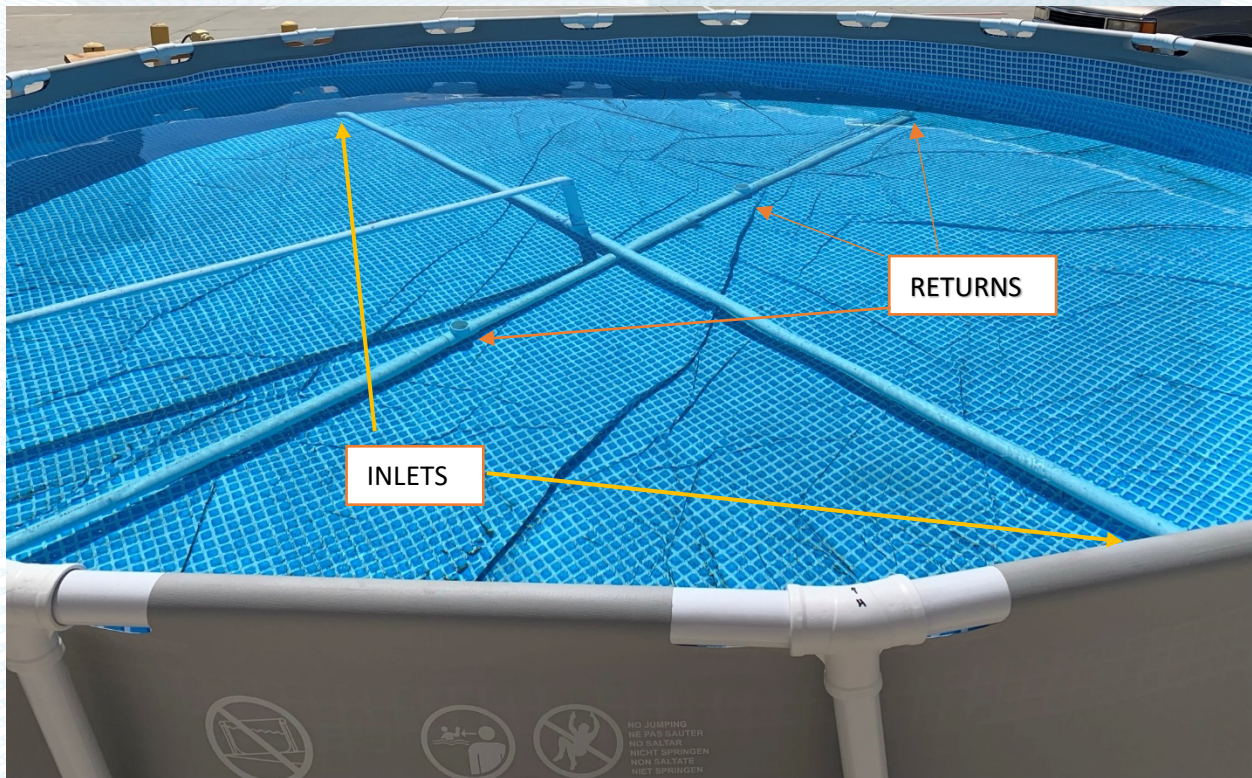
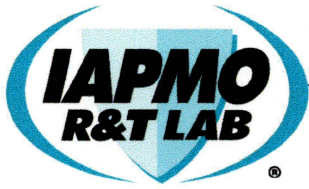

Figure 8- Layout of Inlets and Returns- Same for Both Pools





# TEST REPORT

5001 East Philadelphia Street  
Ontario, California – USA 91761-2816

Ph: 909.472.4100 | Fax: 909.472.4243  
<http://www.iapmortl.org>

**Report Number:** 2295-20498

**Project Number:** 34044

**Report Issued:** July 2, 2020

**Report To:** ASSE International

**Tested For:** KD Enterprises LLC  
4348 Waiialae Ave 315  
Honolulu, HI 96816

**Code/Standard:** NSF/ANSI 50 - 2019

**Product(s) Tested:** The HDC Device

**Test Date(s):** June 5-June 23, 2020

**Test Location:** IAPMO 5001 East Philadelphia Ontario CA 91761

**Conclusion:** The device identified above COMPLIED with the standard for the reduction of chlorine use and hydrostatic pressure.

During the sample run there was a 41% reduction in chlorine use.

**Report Status:** **IN COMPLIANCE**

Reviewed By:

Sal Aridi - Director

*This report replaces number 2295-20491, it was reissued to removed the results that the manufacturer did make a claim for.*

All testing and sample preparation for this report was performed under the continuous, direct supervision of IAPMO R&T Lab, unless otherwise stated. The statement of compliance is based on the test results compared to the standard specifications without considering measurement uncertainty. The observations, test results and conclusions in this report apply only to the specific samples tested and are not indicative of the quality or performance of similar or identical products. Only the Client shown above is authorized to copy or distribute the report, and then only in its entirety. Any use of the IAPMO R&T Lab name for the sale or advertisement of the tested material, product or service must first be approved in writing by IAPMO R&T Lab.



## TEST SPECIMENS

Two test specimens were sent by KD enterprise and received in good condition on April 29, 2020.

### Standard Requirement:

For devices claiming a reduction in chlorine consumption, the mass of chlorine used during the test period shall be a minimum of 25% less than the mass of chlorine used during the baseline period.

For devices claiming a reduction in combined chlorine, the average combined chlorine in the test water measured during the test period shall be a minimum of 25% or 0.20 mg/L, whichever is greater, less than the average combined chlorine in the test water measured during the baseline period.

For devices claiming a reduction in acid consumption, the mass of HCl used during the test period shall be a minimum of 25% less than the mass of HCl used during the baseline period

For devices claiming head loss claim the actual head loss shall not exceed the claimed head loss by more than 5%

For devices claiming hydrostatic pressure test, the device shall show no evidence of rupture, leakage, burst, or permanent deformation when subject to a hydrostatic pressure 1.5 times the manufacturer's maximum operation pressure

### Performance Validation Test Setup:

See Figure 8, a 10,000 gallon tank with the following dimensions was used. The tank was covered and air conditioned.

Height: 5'6"  
Width 8'6"  
Length 46'

A variable frequency pump was used to pull water from the tank at an elevation of 1' from the bottom and push water through an 18" sand filter that has a bed depth of 11". The water then went through a Coates water heater then through the device under test which was installed in a 2 inch sched 40 line parallel to a blank pipe and valved so that it can be isolated. The water then returns to the tank at an elevation of 1 ft below the water surface.

An inline turbidity meter and chlorine/ pH controller were installed to control the chlorine and acid feed pumps. A mixing pump was used to keep the water mixed.

After completion of the baseline run the test tank was drained rinsed refilled and rebalanced. The filter sand was replaced with fresh sand to a bed depth of 11 inches.

When the sand was fresh the filter was backwashed until clean at 38 gpm and rinsed for 30 seconds. When the filter was dirty it was backwashed until it was clean Turbidity < 10 then rinsed until clean.



**Results:**

The mass of chlorine used was measured during the baseline run as well as the sample run; the data is in Table 1.

**Table 1- Mass of Chlorine Used in gm During Each of the 7 Day Runs**

Chlorine 4%	
Baseline Run	Sample Run
34935	20605

During the Sample run the chlorine usage was **41% less**.

**Table 2- Operational Data**

	Baseline Run	Sample Run
Average Total Chlorine ppm	1.94	2.08
Average Combined Chlorine ppm	0.15	0.13
Average Chlorine Use Per Day gm	4991	2944
Total Synthetic Bather Load Used gm	6150	6230
Average Water Temperature °F	83.8	81.1
Average Air Temperature °F	80.3	77.2
Average Flow Rate gpm	26.7	27.6
Conditioned Makeup Water Added gal	2987	2400*
Number of Filter Backwashes	1	1

*\*The amount of water going to drain through the turbidity monitor and chlorine controller was slowed to reduce wasted water.*

Figures 2- 6 show the logs of the data captured during the running of tests; this data was sampled from the return line just upstream of the filter. A couple of spikes of chlorine were due to sensor fouling. During the first 2 days of the baseline run the chlorine and acid ran out in the early morning hours.

Hydrostatic Test:

Rated Pressure: 50 psi  
Test Pressure: 75 psi  
Test Duration: 5 min  
Test Water Temp: 78.9° F

Test Result: **PASS**

Head Loss Test:

Table 3- Pressure Drop Across Sample

Flow gpm	26.2	34.4	50.4	63.4	72.0
Pressure in	0.4	0.9	1.5	2.2	2.6 (differential)
Pressure out	0	0	0.3	0.4	
Pressure Drop psi	0.4	0.9	1.2	1.8	2.6

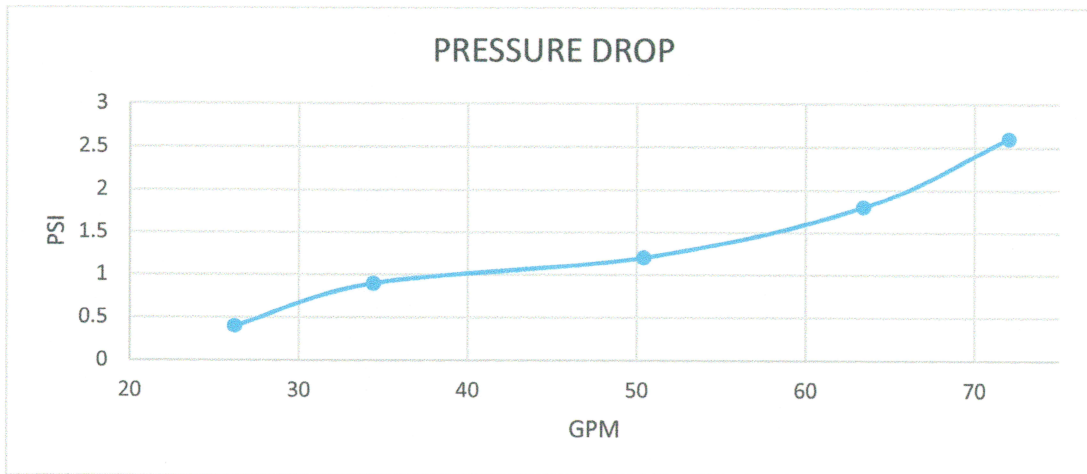

Figure 1-Pressure Drop Across Sample



Figure 2- pH and Free Available Chlorine During the Baseline Run

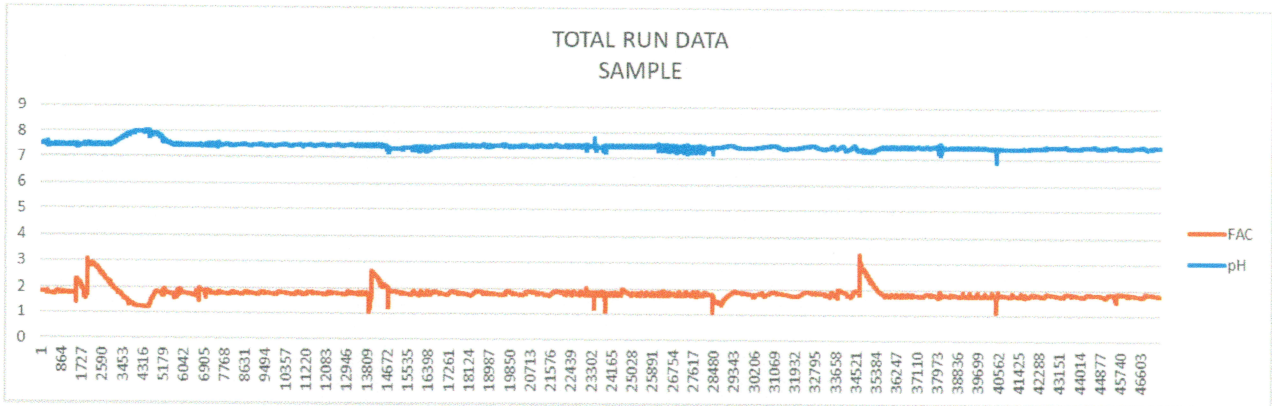

Figure 3- pH and Free Available Chlorine During the Sample Run



Figure 4- Combined Chlorine

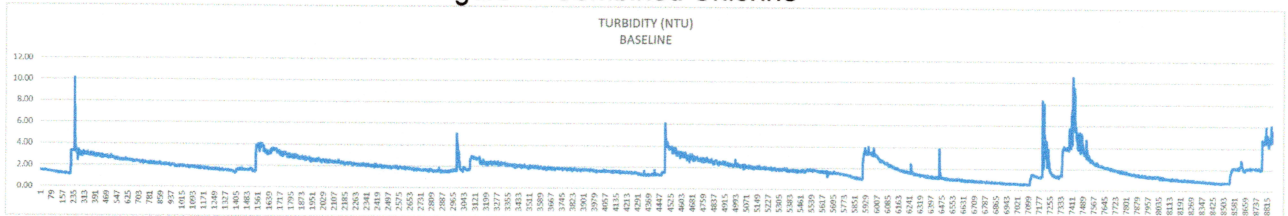

Figure 5- Turbidity During the Baseline Run

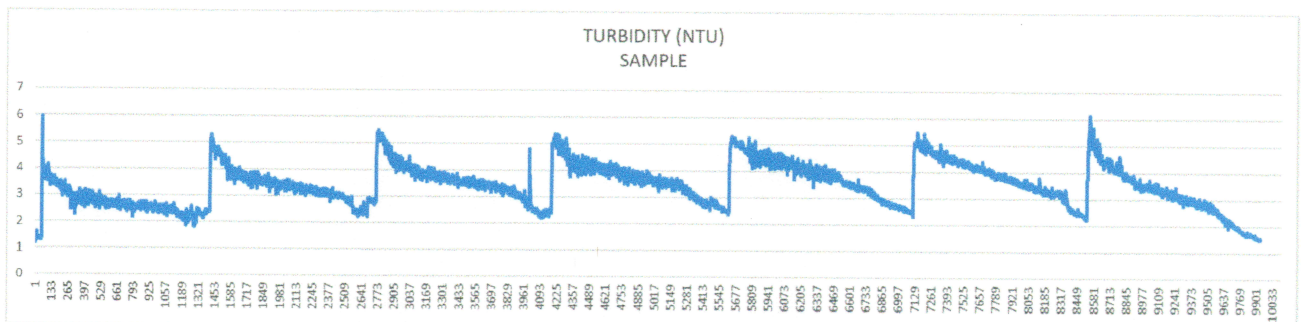

Figure 6- Turbidity During the Sample Run



Figure 7- Sample Under Test

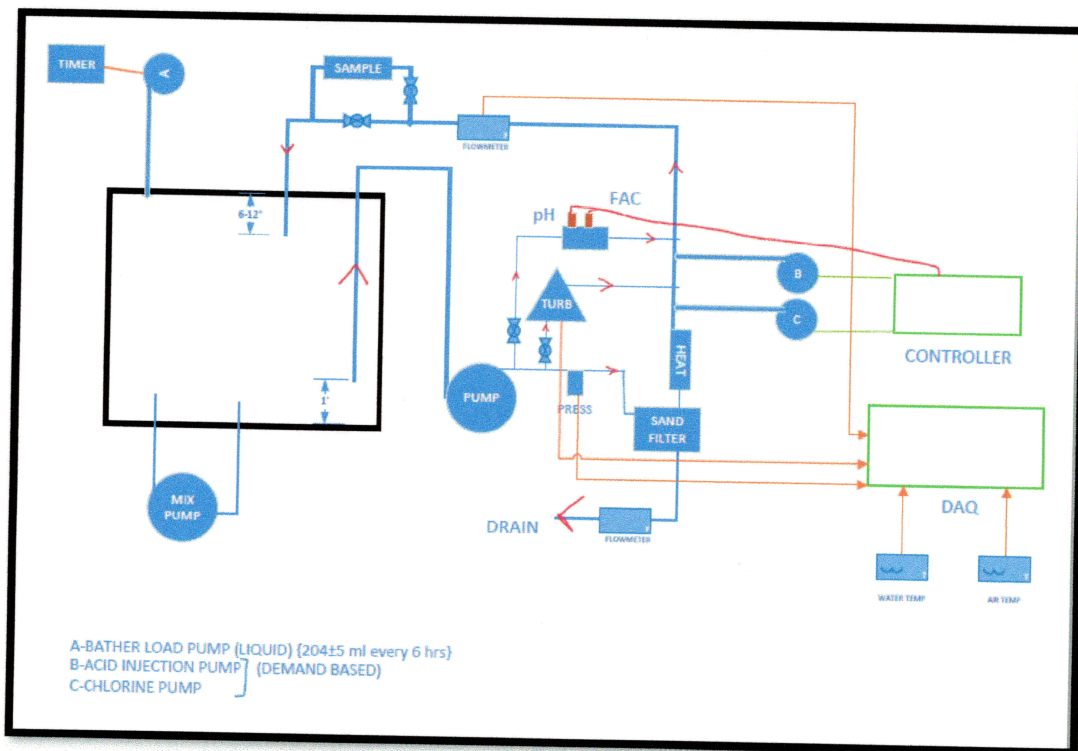

Figure 8- Test Setup